

# SPECIFICATIONS SHEET

## ENSURE™ OXYGEN CONCENTRATOR SYSTEMS

Models: OC-45

### How Does The System Work?

**Pressure Swing Adsorption (PSA)** elements remove nitrogen from air leaving mostly oxygen. First, incoming air is compressed and fed to our proprietary **Stealth** dehumidifier. Second, water vapor is condensed prior to entering the PSA element and automatically evaporated. Third, molecular sieves in the PSA elements adsorb nitrogen from the air. Oxygen levels are concentrated up to 92%. Nitrogen is then exhausted from the PSA element to atmosphere.

### System Features

Guardian Oxygen systems are designed to operate seamlessly with **Ensure** Ozone Systems. Operational parameters function with integrated Smart Relay Technology. Oxygen concentration is monitored with an on-board processor for full **Plasma Block®** or other ozone cell protection.

SPECIFICATIONS	OC45-12-240V
System Control	Low Voltage Dry Contact
Oxygen Concentrators	Three
Oxygen Output Purity	45 LPM @ 87-92% O <sub>2</sub>
Power Requirements	240V, 1 Ø, 15A
Compressors	Three
Oxygen Flow Rates	1-45 LPM
UL Enclosure	NEMA 12, NEMA 4 & 4X
Cooling Method	Air Cooled
Operating Pressure Range	5-14 PSI
Dryer/Filters	Guardian Stealth Technology Dehumidification
Dimensions / Weight	60.0"H x 36.5"W x 13.0"D (Cabinet) / 21.0"D (Compressor Tree) 369 lbs

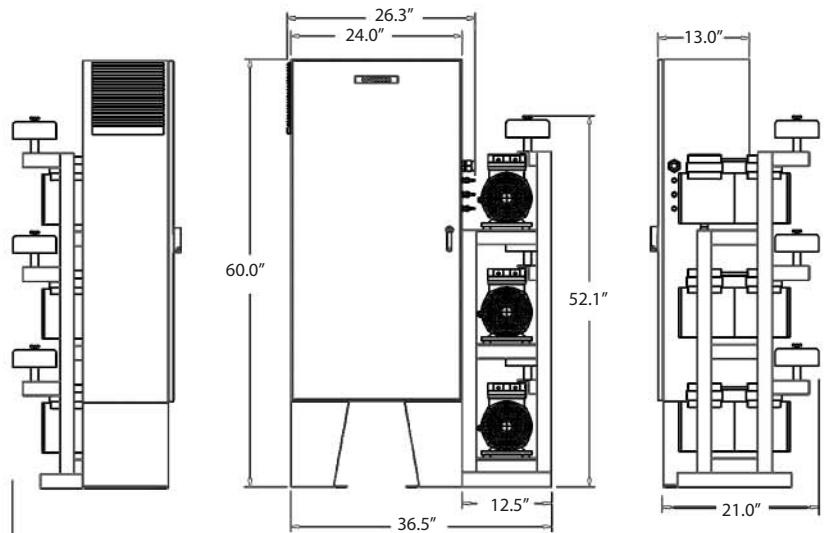

Corporate Headquarters:  
2971-A Oxbow Circle  
Cocoa, FL 32926  
phone: 321-508-3392

Guardian supplies numerous industrial control systems to customers worldwide.



[www.guardianmfg.com](http://www.guardianmfg.com)